

Table 2.

Status	Jumpers
Matching	S4 Close
Working	S4 Open

information from the matched detector correctly. Any information sent by non-matched detector will be ignored.

- Set the receiver as matching status.
- Put the battery in to the detector. Wrong electrode of the battery could cause a serious damage.
- Set the detector as matching status. (table 2.)
- Trigger the detector to send a identifier code.

●Restore the receiver and the detector to working status.

●Set back the front housing of the detector and install it.

Working Status

Set jumper S4 Off for working status. After the first triggered, any continuous trigger in the 20 seconds would not cause alarm. Every 65-minutes, the detector will send a signal to receiver reporting the battery status.

Walk Test

●Power the unit and wait until stabilized (more than 2 minutes)

●Walk test to confirm the correct installation. The LED will turn red as soon as someone go by the intrude direction (fig.7). And the LED will turn green when someone go against the intrude direction and come back in the delay time (fig.8).

Pay Attention

● After testing, check the detector is at working status.

● For saving battery, detector will not send signal continuously if the tamper switch SW is

on for a long time.

●Make sure the receiver/wireless control panel can receive the signal from the detector correctly.

●Wireless product is easy to be interfered by other equipment or the environment. When necessary, please check the environmental situation or adjust the mounting position.

ROISCOK WARRANTY

The warranty is promised by ROISCOK Electronics Ltd. and all its partners to all of the users whom ROISCOK products enthusiast.

All products, within 18 months from the date leaving our plant besides the artificial damage, we take charge of the after service or replacement new one freely. After the time limit, we take charge of lifelong paid service. Regardless of the middle process or/and sale link, all of ROISCOK product has the right to enjoy the after service announced here. Any business agent, the dealer or installer has no

right to refuse to provide the after service.

For quickly service, we hope the user to fill in "Return Products List" in detail together with the units. The goods may return directly to our company, agent, the dealer or installer. When necessary, the user are welcome send "User Complaint Letter" to us.

The Warranty go into effect from the date of July 1, 2007.

ROISCOK Electronics Ltd. is responsible to explain.

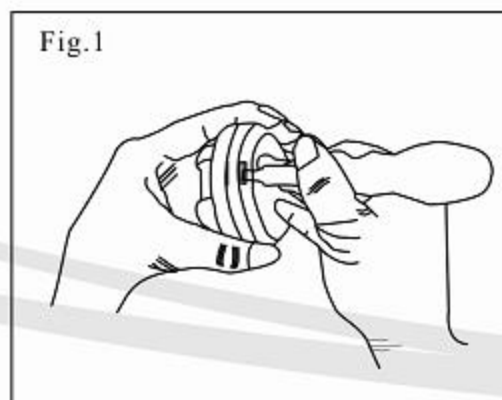

Table 1.

Delay time	Jumper S1	Jumper S2
5 seconds	Open	Open
45 seconds	Open	Close
5 minutes	Close	Open
15 minutes	Close	Close

LED

● Jumper JP2 used for LED On or Off. When turning red indicate alarm, turning green indicate allowing entry.

●For save battery, when alarm the LED will turn only a short time.

●When battery low, the LED will blink.

Matching and Matching Status

After matching detector with receiver/wireless control panel, the control panel could receive the

Specification

- Frequency: 433.92MHz
- Operating Voltage: 3V battery
- Operating Current: 25 μ A(stand- By)
- Alarm time: 2.2 seconds
- Warm-up time: 2 minutes
- RFI Immunity: 25V/m at 10MHz to 1GHz
- Operating Temperature: -20 $^{\circ}$ C to 50 $^{\circ}$ C
- Storage Temperature: -20 $^{\circ}$ C to 60 $^{\circ}$ C
- Size: 95 \times 65 \times 35mm

Delay Time

●The arrow on the front housing and on the PCB is the intrude/alarm direction.

● During the delay time, it allow the user (instead of intruder) to move freely without triggering alarm. The jumper S1 and S2 are used for setting for delay time. (table 1 and fig.2).

- Lower current consumption, longer battery life
- 2 kinds of working status: working status and matching status
- Supervise automatically
- Wireless frequency:433.92MHz

Installations

● Choose the mounting location after careful consideration of the protected area. Do not let the unit face direct to the sunlight or near heat sources (fig.3,4,5)

●Open the front housing by flat screwdriver (fig.1).

●Put in the battery (CR123A). Pay attention to the anode and cathode (fig.2)

●Install the unit on chose place.

●Try to avoid near big metal, strong magnetic field or some high-power wireless equipment.

● Adjust the position, make sure the cover range meet the protect requirement.

The ROISCOK's RK309W is a Wireless Curtain Motion Detector with directional immunity. It has the lower false alarm and weak alarm, lower power consumption and true temperature compensation. With high quality and smart appearance, it is very popular for users. Together with swivel bracket, it can be mounted on wall, corner and ceiling.

RK309W can immunize wrong triggering instead of alarm.

Main Features

- Coverage 8M
- Dual passive infrared detective technology
- With microprocessor
- True temperature compensation
- White light protection
- High RFI immunity up to 25V/m, 1GHz
- Professional lenses
- Wall, ceiling or corner mounting
- Anti-fluorescent interference

RK309W Wireless PIR Curtain Detector

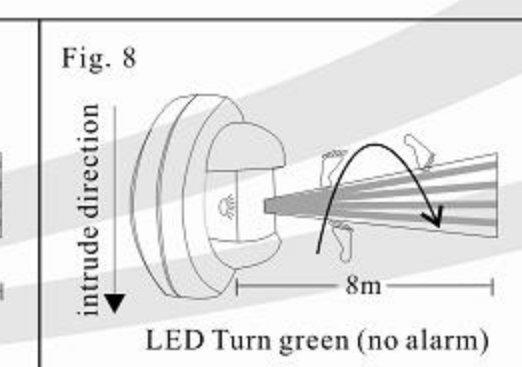
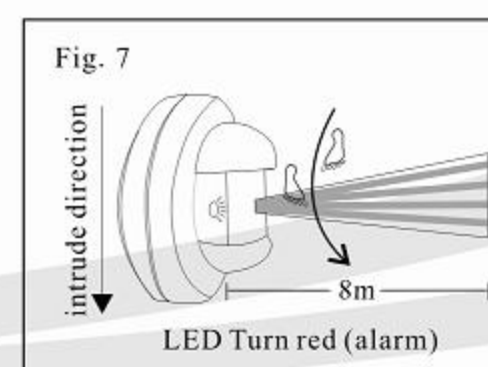
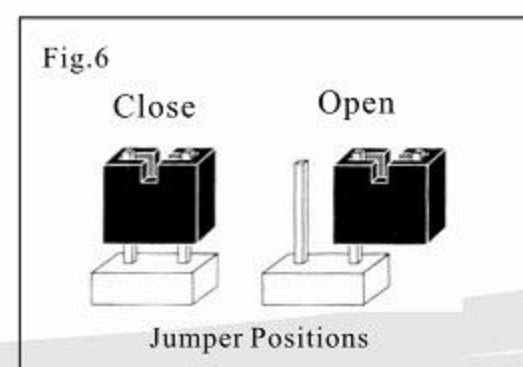
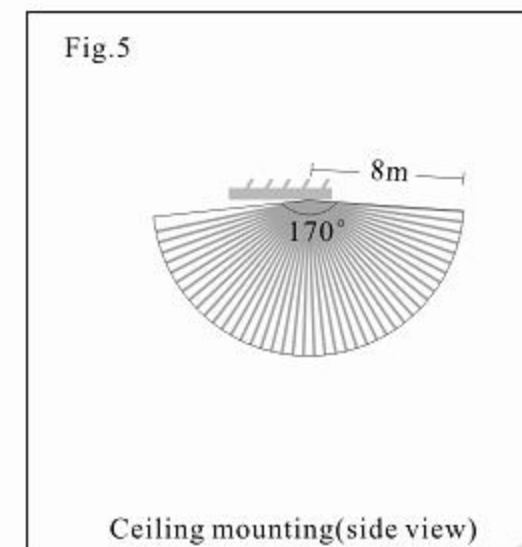
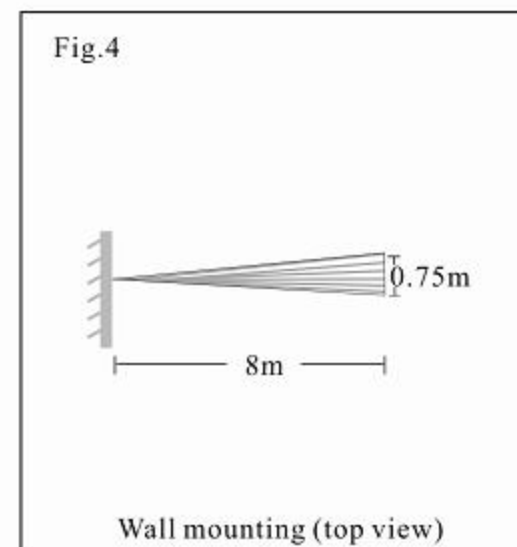
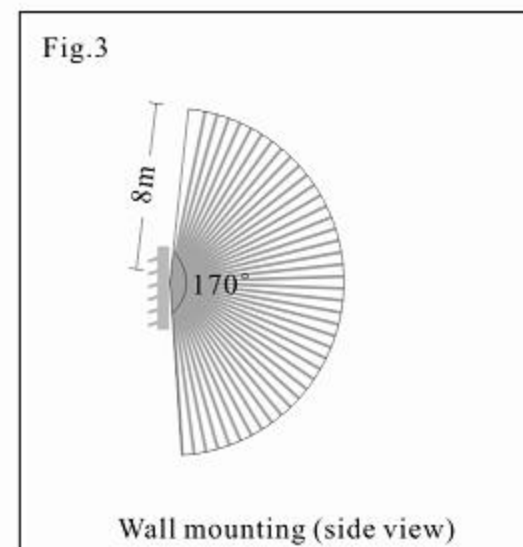
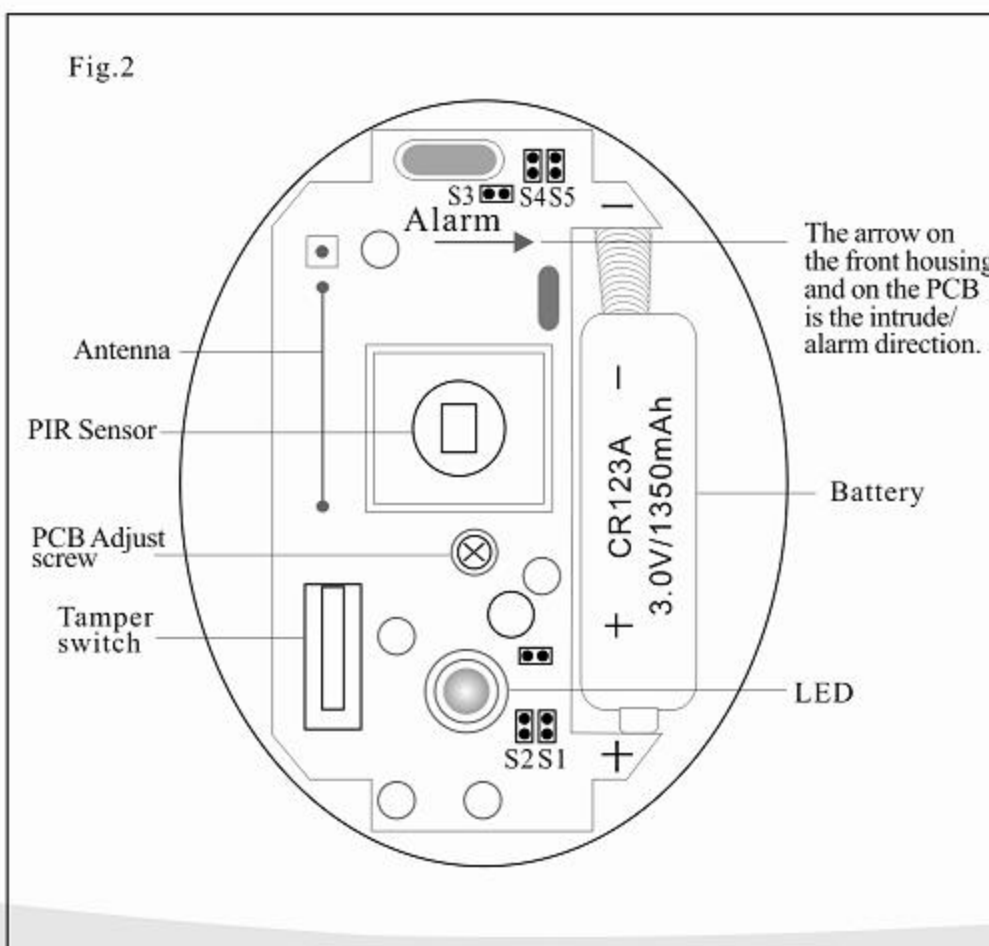

ROISCOK
ROISCOK ELECTRONICS LTD.
www.roiscok.com