

compact



Quick Start Installation Guide

For detailed information please refer to the full **CommPact** Installer Manual provided on our website: www.electronics-line.com



UPGRADING
EVERYDAY
SECURITY

Table of Contents

1. Introduction	3
2. System Installation	3
3. System Programming	5
3.1. Keys Menu Navigation	5
3.2. Enter Installer Programming mode	5
3.3. Selecting a language	5
3.4. Registering Wireless Devices	5
3.4.1. Detectors	6
3.4.2. Keyfobs	8
3.4.3. Wireless keypads	9
3.5. Program Communication to Monitoring Station	9
3.6. Set Up Follow Me Destination	10
3.7. Set Time & Date	11
3.8. Set/Edit Users	11
3.9. Set GPRS Communication	13
3.10. Connect to ELAS	13
4. Testing the System	15

1. Introduction

Thank you for choosing **CommPact** wireless intruder Control Panel. This quick start guide manual describes the main steps for installing and programming the **CommPact** Control Panel using the keypad on the main unit.

2. System Installation

1. Place the drilling template against the wall and mark the mounting holes.
2. Install wall anchors in the appropriate positions.
3. Open the main unit housing.
4. If the AC cable is not connected thread the power cable through the wiring hole on the back cover and connect the cable to the AC power input on the main board (**Figure 1**).

Caution: Do not apply AC power at this stage.

5. In case of using Wired Zone, PGM and Telephone/Line, connect the following to their connectors on the Main Board terminal block (**Figure 2**)
6. If your system supports GPRS communication, insert a SIM card (the SIM card can be placed from the back cover without opening the main unit).
7. Connect the backup Battery pack to the connector (**Figure 3**) on the main board.

Note:

If the siren is activated enter the master user code number (default '1234') to silence the alarm.

8. Mount the control system to the wall
9. Close the front cover and apply AC power.

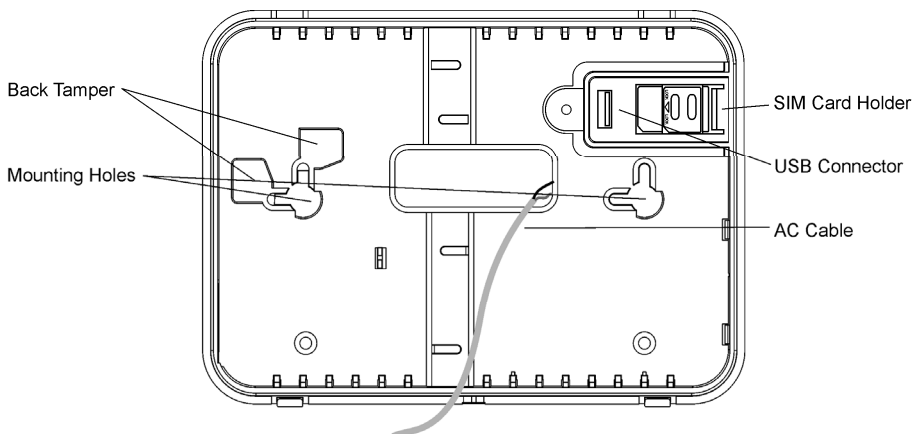

Figure 1: Back cover

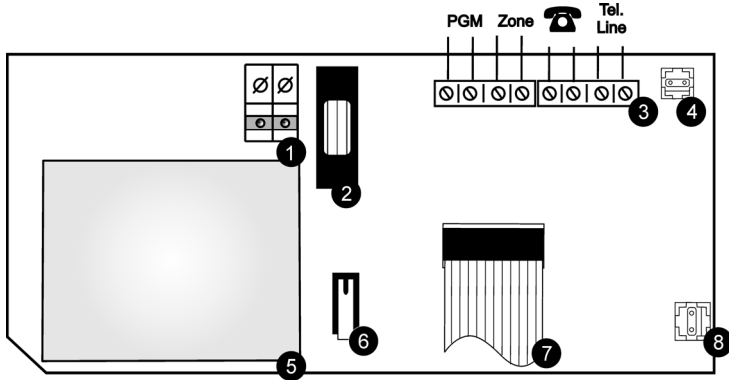

Figure 2: Power Supply and Connections Board

:

- | | |
|--------------------------|---|
| 1. AC Power Connector | 5. AC to AC Transformer |
| 2. AC Fuse | 6. Front Tamper Switch |
| 3. Terminal Block | 7. Flat-Cable Interface Connector to the Main Board |
| 4. Back Tamper Connector | 8. Battery Connector |

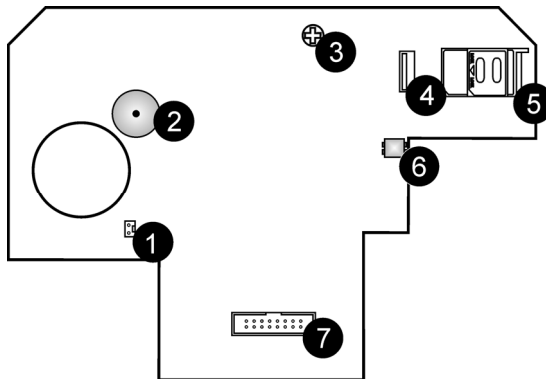

Figure 3: Main board

1. Built-in Siren Connector
2. Buzzer
3. LCD Contrast Control
4. USB Port
5. SIM-Card Holder
6. Speaker Connector
7. Flat-Cable Interface Connector to the Power Supply and Connections Board

3. System Programming

3.1. Keys Menu Navigation

Program the CommPact from the keypad located on the main unit (see **Table 1**).



	Enter / Save (to move to the displayed menu or to save the updated data)
	Cancel the current selection or return to previous menu
	Scroll up or down through the menu options
[1]-[0]	<ol style="list-style-type: none">1. Enter numeric values where required.2. For quick key programming. Press the number keys to access a programming option.3. Edit descriptors.

Table 1: Keypad usage

3.2. Enter Installer Programming mode

1. Go to the default menu and press '√'.
2. Enter your installer code (default code '1111').
3. Using the arrow keys, select '[9] Programming'

3.3. Selecting a language

The **CommPact** supports several languages. For easy operation, change the system language as follows:

1. Go to the main menu select [9]>[7]>[1] (Programming > Initialize > Init All)
2. Select default and press '√'. Select **language** (Voice + LCD display) and press '√'.

3.4. Registering Wireless Devices

Every device has to be registered to the Control Panel in order to be recognized.

It is recommended to register all devices to the control panel before installing. To install the wireless devices/accessories *temporarily* fit them in the desired locations and then perform a range test. Testing may show you should relocate the panel or some of its devices/accessories.

Note:

For wireless siren registration refer to the full installer manual.

3.4.1. Detectors

The **CommPact** supports 33 security zones. Only one detector can be registered to each zone. Zones 1-32 are intended for wireless detectors by default. Zone 33 is an on-board hardware zone (can be configured as NO, NC or EOL).

Step 1: Register a detector

1. Go to the main menu and select [9]>[1]>[1] (Programming> Devices > Zones)
2. Using the arrow keys, select a specific zone and press '√'. The system initiates Registration mode.
3. Send two transmissions from the detector. A confirmation sound is heard after each successful signal (chime sound). After two successful transmissions a confirmation beep is heard.

Sending the transmissions can be done in several ways, as summarized in **Table 2**.

Device	Device Model Number	Sending Transmissions
PIR Detectors	EL-2645	Apply battery power. Place the mode jumper over pins 2 and 3 (Radio Mode); the LED flashes.
	EL-2645PI	OR Depress the tamper switch twice, in rapid succession.
Magnetic Contact	EL-2601	When you apply battery power and the tamper switch is open, the device enters test mode in which a transmission is sent every few seconds. You can terminate the test mode by closing the tamper switch.
Flood Sensor	EL-2661	
Universal Transmitter	EL-2602	
Glass break	EL-2606	
Smoke Detector	EL-2603	Press the test button. Verify that the transmission LED is lit momentarily. Wait five seconds and press the test button again.

Table 2: Transmission sending

4. After the detector is successfully registered the display shows: 'Save?' Press '√' to confirm and continue entering other parameters for the chosen device (see section below) or press X to go back and enroll additional zones.

Step 2: Set detector's parameters

1. Go to the main menu and select [9]>[1]>[1] (Programming > Devices > Zones)
2. Using the arrow keys select a specific zone and press '√'.
3. Set the main parameters for each zone, according to **Table 3**

Quick Key	Option Name	Description and Notes
9>1>1>2	Zone Type	The alarm this zone generates
9>1>1>3	Arm Set	Arming methods in which the zone is included. 1 (F): The zone is included in Full arming 2 (P): The zone is included in Part arming 3 (PE): The zone is included in Perimeter arming
9>1>1>4	Descriptor	Descriptors help identify the device when you operate and program the system.
9>1>1>5	Bell (Siren)	Activate the siren when the zone is triggered
9>1>1>6	Chime	Activate the internal siren when the zone is triggered. Note: To allow the chime option enable Global Chime option [Quick key 7>12]
9>1>1>7	Force Arm	Enables to arm the system even if this zone is not ready. For the force arm feature to function, you must also enable force arming in system options.

Table 3: Parameter set

4. If required scroll through the other menu parameters and modify settings.

Step 3: Test the detectors

1. Go to the main menu and press '√'.
2. Enter your installer code (default code '1111').
3. Enter [7]>[07]>[2] (Service > Transmitters > TX Test) to initiate the TX communication test. This test enables to identify transmitters and test their signal strength.
4. Activate the transmitter to test; the transmitter's details appear on the CommPact LCD and a sequence of tones is heard indicating the transmitter's signal strength.

Signal Strength	Tones	Note:
0-2	1 Tone	If the signal strength is less than 6, place the devices in a better location.
3-5	2 Tones	
6-8	3 Tones	
8-9	4 Tones	

Table 4: Signal strength

In addition the menu shows the detectors status using the abbreviations as seen in **Table 5**.

Item	Description...	Item	Description...
OK	The transmitter is functioning correctly	OS	The transmitter is not synchronized
TA	Tamper condition	NA	The transmitter is inactive
BT	Battery low		

Table 5: Abbreviations

3.4.2. Keyfobs

The CommPact Control System supports up to 19 keyfobs.

Step 1: Register a keyfob

1. Go to the main menu, select [9]>[1]>[2] (Programming > Devices > Keyfobs)
2. Using the arrow keys select a specific keyfob and press '√'. The system initiates Registration mode.
3. Press a button on the keyfob, assuring the keyfob's LED lights up when the button is pressed.
4. Press the same button again.
5. When 'Save?' appears on the Control System's LCD display, press '√'.

Step 2: Set the keyfob's parameters

1. Go to the main menu, select [9]>[1]>[2] (Programming > Devices > Keyfobs)
2. Using the arrow keys select a specific keyfob and press '√'.
3. Set the parameters for each keyfob according to **Table 6**.





Quick Key	Option Name	Description and Notes
9>1>2>2	Type	Controlled or non-controlled. A controlled keyfob causes the system to send arm/disarm event messages to the central station. Non-controlled keyfobs never send arm messages and send a disarm message only if the system is disarmed after an alarm occurrence
9>1>2>3	Descriptor	Descriptors help identify the device when you operate and program the system. Use the  /  key to insert a space
9>1>2>4	KF1 PGM	Defines whether the keyfob can control the PGM with the  /  button.
9>1>2>5	Delete	Delete a keyfob

Table 6: Keyfob parameters

Step 3: Testing the keyfobs

1. Go to the main menu and press '√'.
2. Enter your Installer code (default code '1111').
3. Enter [7]>[07]>[2] (Service > Transmitters > TX Test) to initiate TX communication Test. Review the explanation in Detectors section.

3.4.3. Wireless keypads

Step 1: Register a wireless keypad

The CommPack supports up to four wireless keypads.

1. Go to the main menu, select [9]>[1]>[3] (Programming > Devices > Keypads) .
2. Select the keypad to register and press '√'. The system initiates Registration mode.
3. Press a button on the keypad assuring a LED lights up when the button is pressed.
4. Press the same button again. When 'Save?' appears on the Control System's LCD display, press '√'.
5. Set the keypad descriptor.

Note:

The above procedure refers to keypad EL2620 and EL 2640. For registration keypads EL2621 refer to the full installer manual.

Step 2: Test a keypad

1. Go to the main menu and press '√'.
2. Enter your Installer code (default code '1111').
3. Enter [7]>[07]>[2] (Service > Transmitters > TX Test) to initiate the TX communication test. Review the explanation in Detectors section.

3.5. Program Communication to Monitoring Station

This section describes the main parameters to establish communication between the CommPack and the CMS (Control Monitoring Station).

1. Enter the installer programming menu.
2. Select [5]>[1] (Communication > Accounts).
3. Select the account to be used for CMS report and press '√'.
4. Define the parameters as seen in **Table 7**.

Quick Key	Option Name	Description and Notes
9>5>1>1	Telephone No.	Enter phone number. Use the \varnothing key to enter "T", ",", "P", "+", "*", "#".
9>5>1>2	Protocol	Used to define the account's communication protocol. For CMS accounts select one of the options: IP protocol, SMS Contact ID, SMS SIA, SIA, Contact ID Note: Set account 1 to IP protocol if you use GPRS
9>5>1>3	Communication Interface	Program an account's communication interface. Select PSTN, GSM, or GPRS (GPRS can be used only for the account 1)
9>5>1>4	Two-Way Audio	Enable/Disable two-way audio communication between the Control Panel and the operator at the CMS.
9>5>1>5	Account number	Enter up to eight digits. Enter leading zeros for account numbers of less than eight digits. Use the \varnothing key to enter hexadecimal digits. If the programmed protocol is Contact ID, "A" is not a valid entry in the account number.
9>5>1>6	Call Attempts	The Call Attempts option determines the number of times the system tries to call a telephone number before moving on to the next number in sequence This feature is not available for voice report.
9>5>1>7	Account Type	Select whether the account is Primary or Backup. The first account is always primary, while every other account (that is not a voice report) may be chosen as primary or backup. Each primary account may have one, several, or no backup accounts at all

Table 7: Quick keys

3.6. Set Up Follow Me Destination

Follow-Me feature is designed to notify a user an alarm event has occurred. To set up follow me define relevant accounts as follows;

1. Enter the installer programming menu.
2. Select [5]>[1] (Communication > Accounts)
3. Select an account to be used for Follow Me and press \checkmark .

Note:

Account number 3 is designed for using Follow me feature. It is the only telephone number that can be programmed by the user in the following location (only if defined as SMS or TWA): Main menu > '[5] Follow Me Number'

4. Enter the Follow Me telephone number and press $\sqrt{}$
5. Select the protocol from the following options:
 - Two Way Audio Follow Me
 - SMS Follow Me
 - Voice Report
6. Define the communication interface for Follow me: PSTN or GSM.
7. Scroll through the other menu parameters and press $\sqrt{}$ to confirm.

Note:

Using the ELAS, the number of Follow me destinations by SMS or Email can be expanded.

3.7. Set Time & Date

The time and date are used to stamp events in the event log. Additionally the time is displayed on the LCD.

1. Go to the main menu and press $\sqrt{}$.
2. Enter installer code (default code '1111')
3. Select [7] > [01] (Service > Set Time/Date).
4. Select '[1] Set Time'. Enter the current time and press $\sqrt{}$
5. The display shows '[2] Set Date' option. Enter the current date and press $\sqrt{}$.

Note:

If the time is set in 12hr format, use the  key to toggle between AM and PM.

3.8. Set/Edit Users

The CommPact supports up to 32 individual user codes. Each of these codes is four digits long. The ability to perform an operation is defined by your user code's authorization level. Each code is defined with its own authority level. Follow **Table 8** to view the authorization level assigned to each of the codes.

Notes:

Codes 1-29 can be edited only by the Master code.

Codes 30, 32 can only be edited by the installer. (Code 32 - Installer code, Code 30 the Central Station TWA Code)

Code Number	Authorization Level	Description
1	Master Code	With the master code, you can edit all other user codes except the Installer code and the Central Station TWA Code. Caution: The default master code is 1234. Change this code immediately after installing the system!
2-19	Controlled Codes	When you use a controlled user code for arming and disarming, the control system notifies the central station with an Arm/Disarm event message
20-25	Non-controlled Codes	Non-controlled codes do not cause the system to send Arm/Disarm event messages to the central station.
26-27	Limited Codes	Valid only for 24 hours. These codes are "controlled"
28	Duress Code	Designed for situations where the user is being forced to operate the system.
29	Telecontrol Code	Designed to enable the user to perform a number of tasks via their telephone when establishing remote connection to the system via the phone.
30	Central Station TWA Code	Designed to enable the central station's operator to establish two-way audio communication with the Control System within ten minutes after an alarm or to stop the bell.
32	Installer Code	The installer code grants access to the programming menu and the service menu. Caution: The default Installer code is 1111. Change this code immediately after installing the system!

Table 8: Authorization level

❖ **To Set/Edit user code**

1. Go to the main menu and press '√'.
2. Enter master code (default code '1234')
3. Select '[4] User Codes'
4. Select the code to edit and press '√'.
5. The display shows '[1] Edit Code' and Press '√'.
6. Type the new code and press '√' to confirm
7. Scroll down to '[2] Descriptor' and press '√'
8. Type user name and press '√' to confirm

9. Press **X** and select another user.
10. Repeat stages 4–9 to set the code for additional users.

Notes:

To delete the code, enter: '0000'

The installer and master codes cannot be deleted.

3.9. Set GPRS Communication

To establish GPRS communication:

1. Make sure the SIM card ID is installed inside the communication module.

Note:

If you need to install a new SIM card on the communication module and you use PIN code, it should be programmed in the control system before inserting the SIM card in the Main Board.

2. Edit the APN (Access Point Name) of your GPRS connection:
 - a. Go to the main menu and press $\sqrt{}$.
 - b. Enter installer code (default code '1111')
 - c. Select **[9] > [5] > [7] > [6] > [1]** (Programming > Communications > Internet > GPRS Options > APN)
 - d. Enter the APN name provided by the cellular provider.
 - e. Press $\sqrt{}$ once editing operation is done.

3.10. Connect to ELAS

The Electronics Line Application Server (ELAS) handles all communication between the system, service providers and web users, enabling monitoring and control to be performed via the Web. Internet settings are mostly pre-programmed in the Control Panel default settings. The only settings you need to program are the Control Panel ID & password (provided by ELAS administrator).

Note:

To enable GPRS communication Account 1 protocol must be defined as IP and the account interface should be defined as GPRS.

Program the CPID

1. Go to the main menu and press $\sqrt{}$.
2. Enter your installer code.
3. Enter **[9] > [5] > [7] > [3]** (Programming > Communications > Internet > CPID).
4. Enter an ID using the alphanumeric keypad. The ID length is up-to 16 characters. The ID must begin with a letter.
5. Press $\sqrt{}$.

Program the Control Panel password

1. Go to the main menu and press $\sqrt{}$.

2. Enter installer code.
3. Enter [9] > [5] > [7] > [4] (Programming > Communications > Internet > CP Password).
4. Enter a password using the alphanumeric keypad. The password length is up to 16 characters. The password must begin with a letter.
5. Press '√'.

If the Control Panel does not succeed to connect to the ELAS, an error message is displayed. **Table 9** indicates the optional error messages.

LCD display	Trouble Description	Action
MEDIA LOSS GPRS MODULE	GPRS network fail	Check the SIM card placement, make sure it supports GPRS, check SIM PIN code. Check APN definitions (Name [95761], User name [95762] and password [95763])
XML FAIL	CP fails to communicate with the XML Proxy	Check ELAS IP address (Quick key [9571])

Table 9: Optional error messages

4. Testing the System

It is important to fully test the system after installation. CommPact has several testing tools to verify that the system will operate optimally, including the wireless communication

1. Go to the main menu and press '√'
2. Enter installer code
3. Decide which quick key should be selected as summarized in **Table 10**.

Quick key	Option	Description and Notes
7>0>3	WL Siren Test	The external siren is sounded briefly
7>0>4	Siren Test	Built-in siren is sounded briefly
7>0>6	Walk Test	A list of registered devices appears. Trigger each device; when the system receives a successful transmission from a device the device is removed from the list
7>0>7>1	TX List	This test is a scrollable inventory of all registered devices and their last reported status. Using the arrow buttons, scroll through the devices list. The devices list displays the zone/device number or descriptor.(Press the √ key to toggle the display) , the signal strength of the last received transmission and the last received status of the transmitter
7>9>1	GSM Signal Strength	Display the signal strength of the cellular network. In severe cases of low GSM signal consider using external GSM antenna.
7>9>2	RF RSSI level	Measure the RF RSSI level (RF noise measured by the systems' receiver). The result in levels from 1 to 9 is similar to the level of detector transmitter's signal strength. It is recommended that the gap between the RF noise level and the TX signal strength be at least 2. For example, if the RF RSSI level is 5 and the TX signal strength is 6, consider relocation of the Control Panel or its peripherals, or use Repeater (EL-2635).
5	Follow Me	Enter telephone number and perform a test to ensure follow me is operating
6>1	View Event Log	Displays the last 1022 events of the system. The event displays type of event, event time and the zone number. In addition it indicates if the event has been reported to the CMS as follows: R : Report Sent, F : Report Failed, C : Report Canceled, N : No Report, D : Disable – Not reported to CMS

Table 10: Quick key

Electronics Line 3000 Ltd. Limited Warranty

EL and its subsidiaries and affiliates ("Seller") warrants its products to be free from defects in materials and workmanship under normal use for 24 months from the date of production. Because Seller does not install or connect the product and because the product may be used in conjunction with products not manufactured by the Seller, Seller can not guarantee the performance of the security system which uses this product. Sellers' obligation and liability under this warranty is expressly limited to repairing and replacing, at Sellers option, within a reasonable time after the date of delivery, any product not meeting the specifications. Seller makes no other warranty, expressed or implied, and makes no warranty of merchantability or of fitness for any particular purpose. In no case shall seller be liable for any consequential or incidental damages for breach of this or any other warranty, expressed or implied, or upon any other basis of liability whatsoever. Sellers obligation under this warranty shall not include any transportation charges or costs of installation or any liability for direct, indirect, or not be compromised or circumvented; that the product will prevent any persona; injury or property loss by intruder, robbery, fire or otherwise; or that the product will in all cases provide adequate warning or protection. Buyer understands that a properly installed and maintained alarm may only reduce the risk of intruder, robbery or fire without warning, but is not insurance or a guaranty that such will not occur or that there will be no personal injury or property loss as a result. Consequently seller shall have no liability for any personal injury, property damage or loss based on a claim that the product fails to give warning. However, if seller is held liable, whether directly or indirectly, for any loss or damage arising from under this limited warranty or otherwise, regardless of cause or origin, sellers maximum liability shall not exceed the purchase price of the product, which shall be complete and exclusive remedy against seller. No employee or representative of Seller is authorized to change this warranty in any way or grant any other warranty.

WARNING: This product should be tested at least once a week.

CAUTION: Risk of explosion if battery is replaced by an incorrect type. Dispose of used batteries according to local regulations.

Contacting Electronics Line 3000 Ltd.



UPGRADING
EVERYDAY
SECURITY



International Headquarters:

Electronics Line 3000 Ltd.

14 Hachoma St., 75655

Rishon Le Zion, Israel

Tel: (+972-3) 963-7777

Fax: (+972-3) 961-6584

All rights reserved.

No part of this document may be reproduced in any form without prior written permission from the publisher.